

MicronNav 200 System

Hardware Manual

0734-SOM-00002 Rev 03



© Trittech International Ltd

The copyright in this document is the property of Trittech International Ltd. The document is supplied by Trittech International Ltd on the understanding that it may not be copied, used, or disclosed to others except as authorised in writing by Trittech International Ltd.

Trittech International Ltd reserves the right to change, modify and update designs and specifications as part of their ongoing product development programme. All product names are trademarks of their respective companies.

Open Source License Statement: This product may include software code developed by third parties, including software code subject to the GNU General Public License Version 2 ("GPLv2"). We will provide upon request the applicable GPL source code files via a storage medium for a nominal cost to cover shipping and media charges as allowed under the GPL. This offer is valid for a 3 year period from first manufacture of this product.

General Public License ("GPLv2") Inquiries: Please direct all GPL inquiries to the following address:

Trittech International Ltd
Peregrine Road
Westhill Business Park
Westhill, Aberdeenshire
AB32 6JL, UK

Table of Contents

Warning Symbols	4
Help & Support	5
Introduction	6
General Overview.....	6
How does the Trittech USBL System Work?	7
Technical Specifications	10
Physical and Acoustic Details	10
MicronNav 200 Surface Hub.....	11
USBL Dunking Transducer.....	12
Micron Modem.....	13
Battery Modem.....	14
Battery Modem Charger	15
Electrical Connections and Pin-Outs	16
MicronNav 200 Hub.....	16
Trittech Micron Connector	18
Using the MicronNav Hub	19
Checking the MicronNav Hub Status	19
System Installation	20
Using the MicronNav System with Trittech Sonars	20
Reducing Magnetic Interference	20
Mounting the USBL Dunking Transducer.....	21
Mounting the USBL Dunking Transducer to a Vessel.....	23
System Mobilisation	24
Pre-Dive ROV Installation Checklist	24
Pre-Dive System Checklist	24
Operational Checklist	25
Troubleshooting	26
Maintenance	29
General guidance	29
After Use.....	29
Equipment Storage	29

Warning Symbols

Throughout this manual the following symbols may be used where applicable to denote any particular hazards or areas which should be given special attention:



Note

This symbol highlights anything which would be of particular interest to the reader or provides extra information outside of the current topic.



Important

When this is shown there is potential to cause harm to the device due to static discharge. The components should not be handled without appropriate protection to prevent such a discharge occurring.



Caution

This highlights areas where extra care is needed to ensure that certain delicate components are not damaged or changes that will affect the operation and performance of the equipment.



Warning

DANGER OF INJURY TO SELF OR OTHERS

Where this symbol is present there is a serious risk of injury or loss of life. Care should be taken to follow the instructions correctly and also conduct a separate Risk Assessment prior to commencing work.

Help & Support

First please read this manual thoroughly (particularly the Troubleshooting section, if present). If a warranty is applicable, further details can be found in the Warranty Statement, 0080- STF-00139, available upon request.

Tritech International Ltd can be contacted as follows:



Mail

Tritech International Ltd
Peregrine Road
Westhill Business Park
Westhill, Aberdeenshire
AB32 6JL, UK



Telephone

+44 (0)1224 744111



Email

support@tritech.co.uk



Website

www.tritech.co.uk

Prior to contacting Tritech International Ltd please ensure that the following is available:

1. The Serial Numbers of the product and any Tritech International Ltd equipment connected directly or indirectly to it.
2. Software or firmware revision numbers.
3. A clear fault description.
4. Details of any remedial action implemented.



Contamination

If a product has been used in a contaminated or hazardous environment you must de-contaminate the product and report any hazards prior to returning the unit for repair. Under no circumstances should a product be returned that is contaminated with radioactive material.

The name of the organisation which purchased the system is held on record at Tritech International Ltd and details of new software or hardware packages will be announced at regular intervals. This manual may not detail every aspect of operation and for the latest revision of the manual please refer to www.tritech.co.uk.

Tritech International Ltd can only undertake to provide software support of systems loaded with the software in accordance with the instructions given in this manual. It is the customer's responsibility to ensure the compatibility of any other package they choose to use.

Introduction

General Overview

The MicronNav 200 system is the latest generation of Ultra Short Base Line (USBL) positioning system from Tritech. The system is designed for small vehicles and diver supporting applications.

The system benefits from a number of new features including data transfer interleaved with USBL positioning, software integration into Google Maps™, smaller, more accurate USBL Dunking Transducer and compatibility with the new Micron Battery Modem.



The system comprises a subsea Micron Modem or Battery Micron Modem, a surface USBL transducer with integral magnetic compass and pitch/roll sensors, a surface MicronNav 200 interface hub and bespoke operating software under control of a topside PC/laptop.

The MicronNav 200 uses spread spectrum acoustic technology. This provides a robust method for communication between the dunking transducers and the vehicle Micron Modem/Micron Battery Modem.

The USBL Dunking Transducer can provide 180degree hemispherical coverage below the transducer, which allows vehicle tracking in very shallow water. Omni-directional coverage is provided by the Micron Modem and Micron Battery Modem.

The Micron Modem is a stand-alone device which either responds to acoustic interrogation from the USBL Dunking Transducer (Transponder mode) or is triggered by RS232 / RS485 (responder mode) through the main port. The Responder trigger can come either from the auxiliary port on a Tritech Micron Sonar, or directly from the MicronNav 200 interface hub.

Both the USBL Dunking Transducer and the Micron Modem/Micron Battery Modem can be commanded to switch from positioning mode to data transfer mode, allowing the same hardware to be used to establish an underwater acoustic communications link.

How does the Tritech USBL System Work?

The quality of acoustic data transmission in water using conventional single frequency systems suffers considerably from multi-path phenomena. Sound transmitted from the sending modem arrives at the receiving unit via the direct path, and via a series of secondary paths, due to reflections from the sea surface and sea bottom. This can often result in the loss or corruption of transmitted data. In addition, conventional systems have poor immunity to the continuously varying background sea noise (such as wave noise).

Tritech's Spread Spectrum technology however does not concentrate the acoustic energy in one waveband but produces a transmission which is linearly varied between 20 kHz and 28 kHz (known as a CHIRP waveform). By correlating the received signals with the CHIRP waveform, it is possible to achieve superior performance in challenging multi-path environments. In addition, identification of a unique transmission signature allows signals to be detected in extremely noisy conditions, to the extent that communication is successful even when the signal to noise ratio is as low as -6dB. This means that data streams can be successfully detected which are considerably below the background noise level.

Transmission Characteristics

Transmission characteristics are dependent on a variety of operating conditions which can significantly reduce operating range:

- 40bits/s or 100bits/s (spread spectrum), higher data rates will reduce expected range capability
- The presence of thermoclines
- The presence of acoustically reflecting surfaces within the operating environment
- Ambient noise
- Salinity
- Volume reverberation
- Surface and seabed reflectivity
- Significant Doppler shifts present, due to the relative movement between two communicating Modems

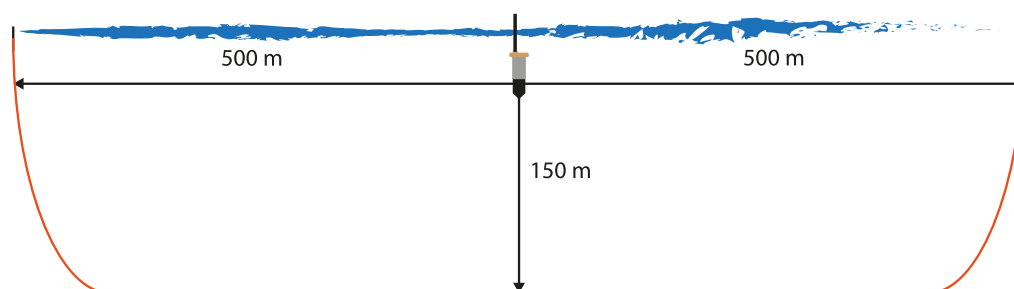

Typical Horizontal & Vertical Range Capability

What makes up a Tritech MicronNav System?

The standard system comprises of the following equipment:

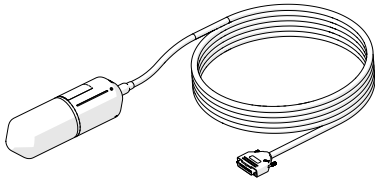
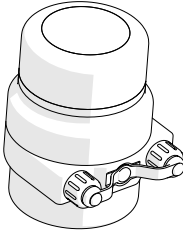
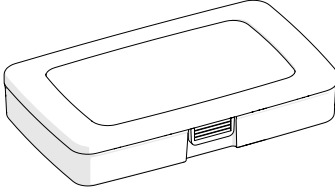
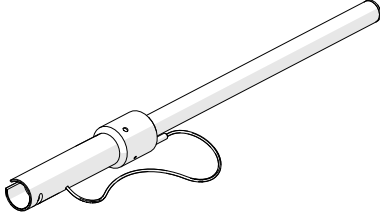
Part Number	Description	Image	Quantity
S11175	<p>MicronNav 200 Hub</p> <p>This is the surface interface for the system and is connected to the computer / laptop via a USB cable</p>		1
S11950	<p>USBL Dunking Transducer</p> <p>This is the subsea interface for the system, responsible for communicating acoustically with the modems and contains an AHRs sensor</p>		1
S11960	<p>Micron Modem</p> <p>A standard system includes a single modem. More can be purchased as necessary</p>		1
S08155	<p>MicronNav Connector Kit</p> <p>This provides the user with connectors and buckets for the D type and Din connectors used on the hub and a USB cable</p>		1
S12639	<p>0.5 Metre Carbon Fibre Mounting Pole</p>		1

Additional Equipment

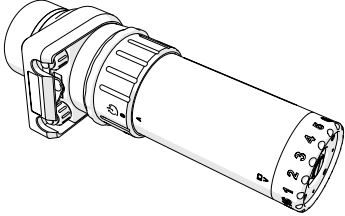
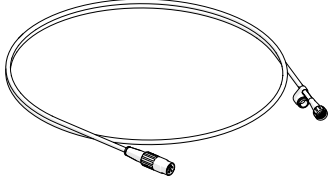
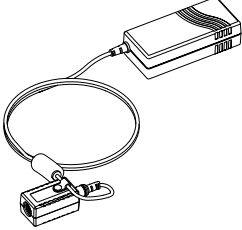
Part Number	Description	Image	Quantity
<p>S11932</p>	<p>Battery Modem</p> <p>This has all the same features that a normal modem has, but with the added convenience of an internal battery. This is not part of the standard system and can be purchased separately. The Modem and Battery modem can be configured to work as an Acoustic Modem or as a Data Modem.</p>		<p>1</p>
<p>S11992</p>	<p>6 pin Din Connector to Micron Connector (2 metre)</p> <p>This cable is wired for both power and communications and allows for configuration of micron devices such as modem and sonar. This is not standard equipment and may be purchased separately.</p>		<p>1</p>
<p>S12630</p>	<p>Battery Modem Charger</p> <p>Used in conjunction with the 6 pin Din connector to Micron connector (S11992). Plugs into main port of the battery modem to charge the modems internal battery.</p>		<p>1</p>

Technical Specifications

Physical and Acoustic Details

System	
Positioning technology	Ultra Short Baseline (USBL)
Frequency band	20 – 28 kHz
Data rate	40 bits/s or 100 bits/s (spread spectrum)
Tracking range *	500 m Horizontal, 150 m Vertical
Range accuracy **	± 0.2 m
Bearing accuracy	1° RMS (determined by USBL integrated heading sensor)
Pitch & Roll accuracy	0.2° Static / 0.5° Dynamic (typical)
Targets tracked	1 Responder or up to 254 Transponders
Doppler tolerance	± 5 m/s

* Range is dependent on operating conditions and data rate in use

** ± 2% of 10 m slant, ± 0.2% of 100 m slant, ± 0.04% of 500 m slant - assumes correct speed of sound.



Drawings are not to scale. Dimensions in millimetres (mm) unless otherwise stated.

MicronNav 200 Surface Hub

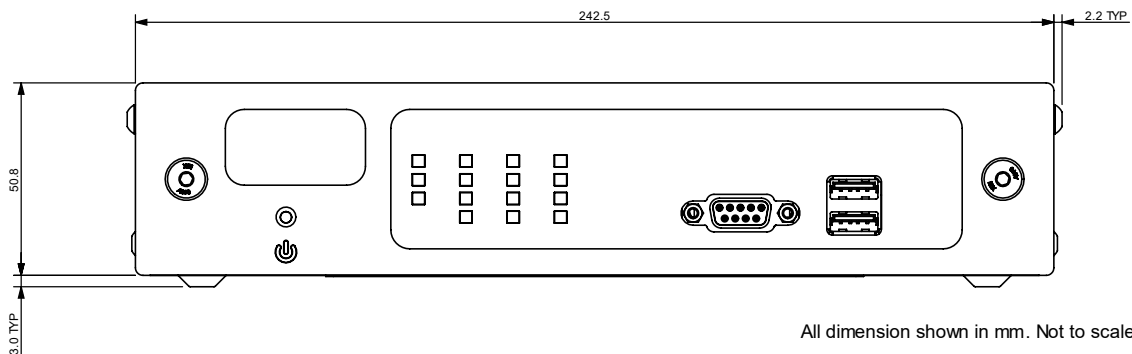
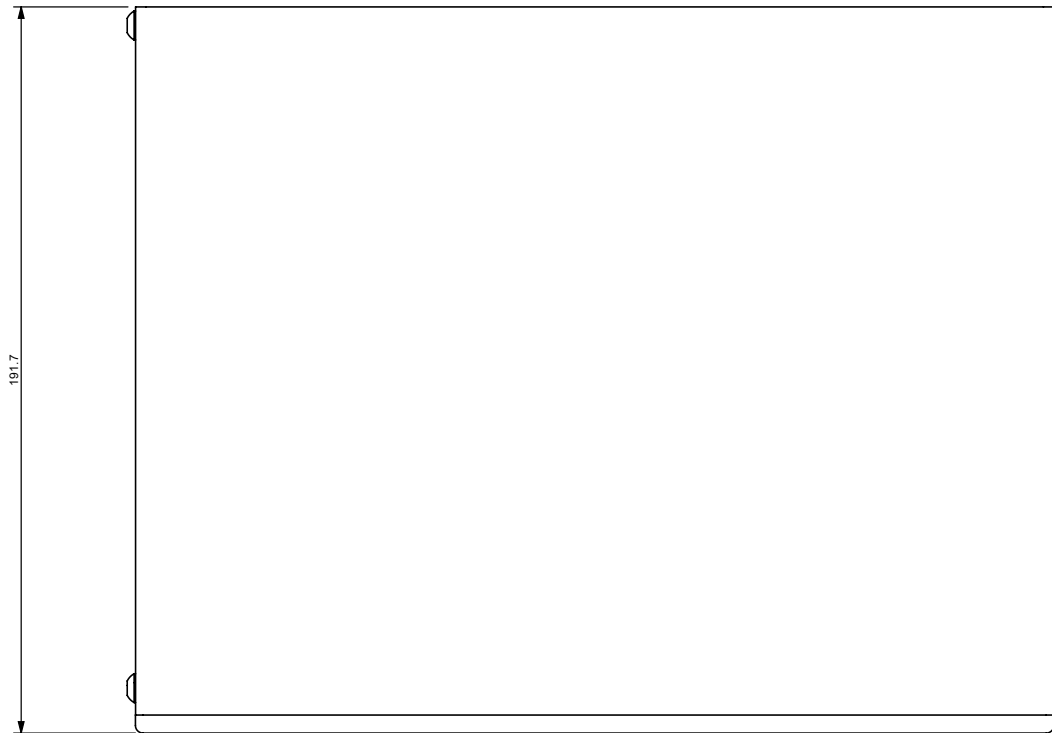

All dimension shown in mm. Not to scale.

MicronNav 200 Surface Hub	
Power requirement (AC or DC)	90 - 264 Vac (47-63 Hz) or 15 - 36 Vdc
Power consumption	8.5 W from either source (with no external load)
Output voltage	33 V (when on AC Supply), 31.5 V (when on DC supply)
Dimensions	232 x 185 x 52 mm (width, depth, height)
Weight	1.4 kg
Material	Stainless Steel housing with Anodised Aluminium front fascia
Temperature rating	5° to 35°C (operational), -20° to 50°C (storage)

USBL Dunking Transducer

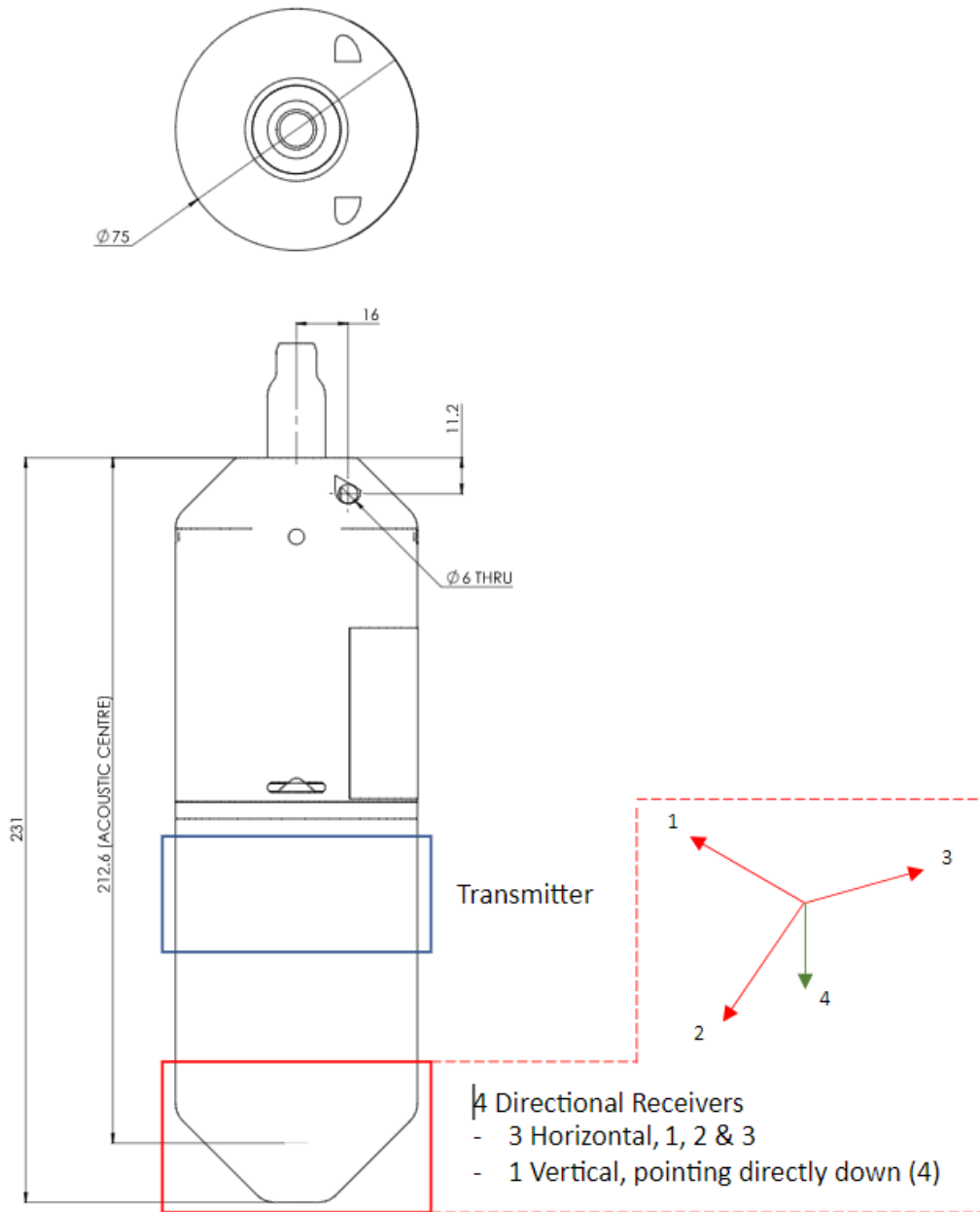

USBL Transducer	
Transmit source level	173 dB re. 1 μ Pa at 1 m
Deck cable length	10 m standard (20 m, 50 m options)
Depth rating	30 m
Dimensions	75 x 250 mm (diameter, length)
Weight in air	1.0 kg
Weight in water	0.1 kg
Temperature rating	-10° to 35°C (operational), -20° to 50°C (storage)

Micron Modem

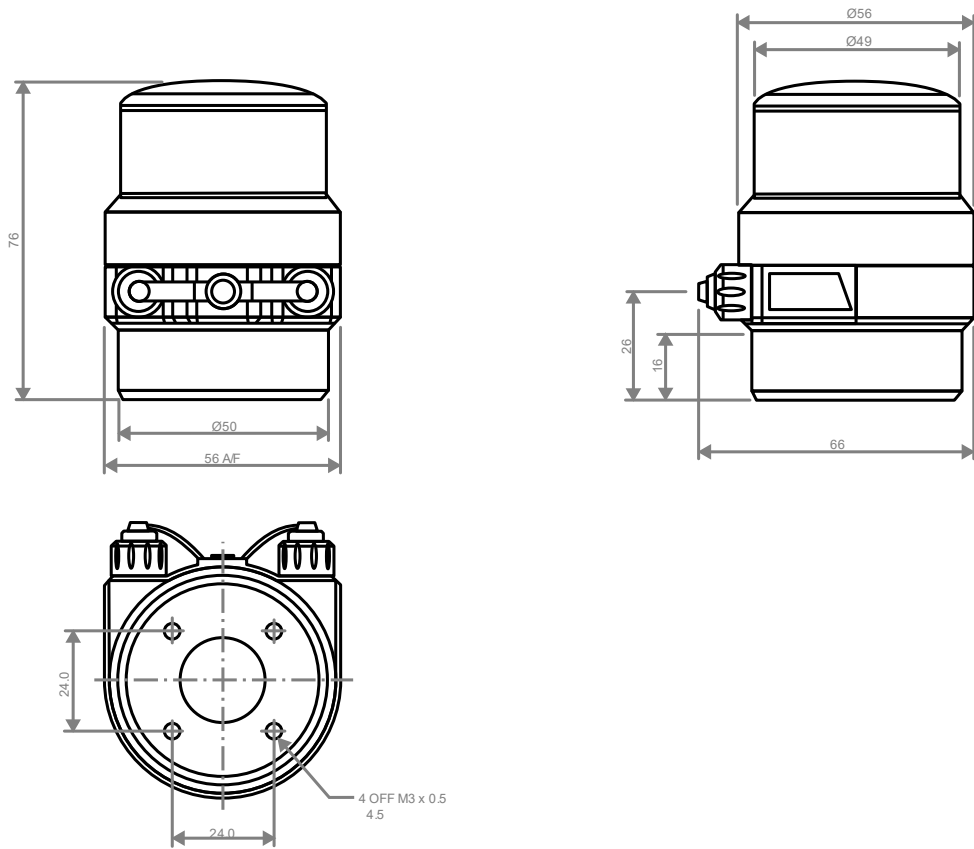

Modem/Transponder/Responder	Micron Modem	Micron Battery Modem
Beam pattern	+/- 90°, Omni-directional	
Transmitter source	169 dB re 1 µPa at 1 m	
Communications protocol	RS232 or RS485 (internally set)	
Depth rating	750 m	
Power Supply	12 – 48 Vdc	n/a
Power consumption	3.5 W transmitting 0.28 W receiving	3.5 W transmitting 0.05 W receiving
Dimensions	56 x 79 mm (depth, height)	56 x 206 mm (depth, height)
Weight in air	0.24 kg	0.89 kg
Weight in water	0.08 kg	0.45 kg
AC Charger	N/A	90 – 264 Vac 47- 63 Hz, 18 W charging
Temperature rating *	-10° to 35°C (operational), -20° to 50°C (storage)	

* Battery Modem operational temperature limited to no less than 10° during charging or while on external power.

Specification subject to change in line with Tritech’s policy of continual product development

Battery Modem

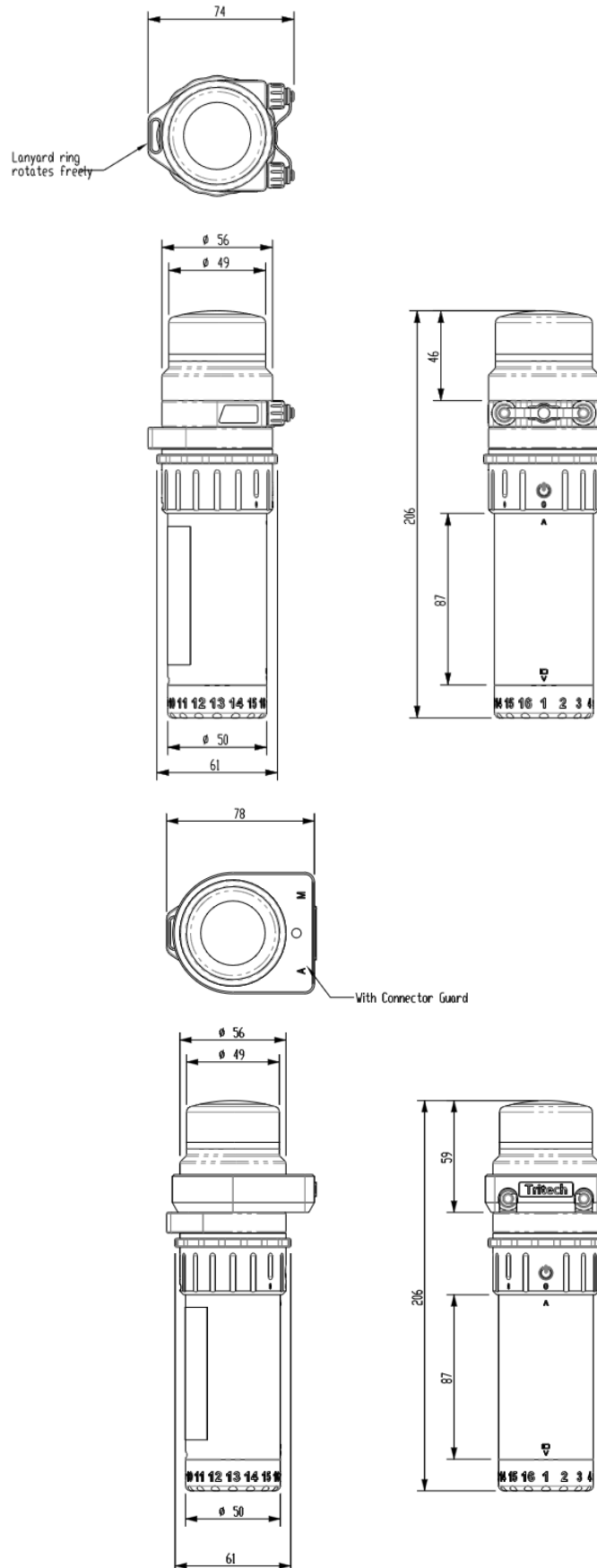

Battery Modem Charger

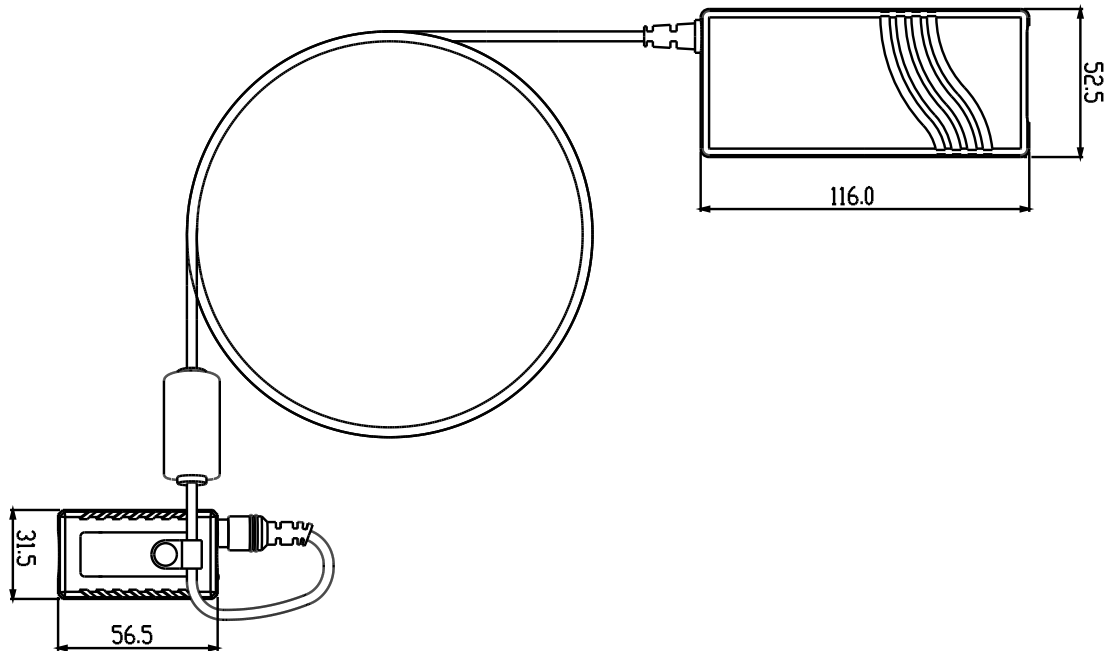

Connect the 6 pin Din Connector to Micron Connector (S11992) onto the battery modem charger to enable connection with the battery modem for charging.



The Battery modem can be connected for charging using either the MAIN Port or the AUX Port.

Yellow LED ON indicates battery modem is connected and charging.
LED OFF indicates battery modem is fully charged or disconnected.



Green LED indicates charger is powered ON.

Electrical Connections and Pin-Outs

MicronNav 200 Hub

CONNECTOR FACE VIEWS

- ◆ Do not exceed specified maximum current ratings
- ★ Pin function is configured by internal connections
- Handshaking pins are internally connected together on each port, but not used for operation.

Ports A-C Electrical Connection

DE-9
Connector Face View

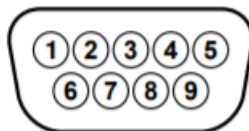

	PORT A		PORT B			PORT C		
	RS232	RS485	RS232	RS485	RS422	RS232	RS485	ARC NET
1	←		NA ●			→		
2	RX	A	RX	A	TX.A	RX	A	LAN.A
3	TX	B	TX	B	TX.B	TX	B	LAN.B
4	←		NA ●			→		
5	←		COMMS.GND			→		
6	←		NA ●			→		
7	RTS	NA	NA	NA	RX.B	NA ●		
8	CTS	NA	NA	NA	RX.A	NA ●		
9	←		NA ●			→		

Port D Electrical Connection

Port D socket should be used with a DIN-45322 (6 pin) plug and should be wired as follows:

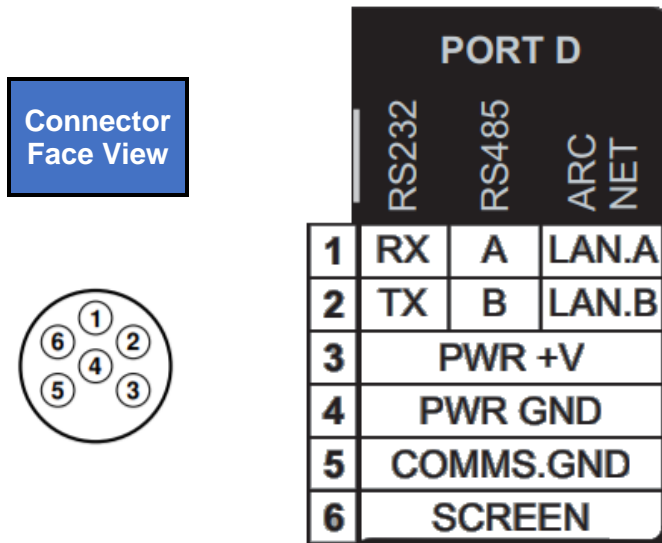

AIF (ARCNET) Port Electrical Connection

DA-15 AIF (ARCNET) connector, and should be wired as follows:

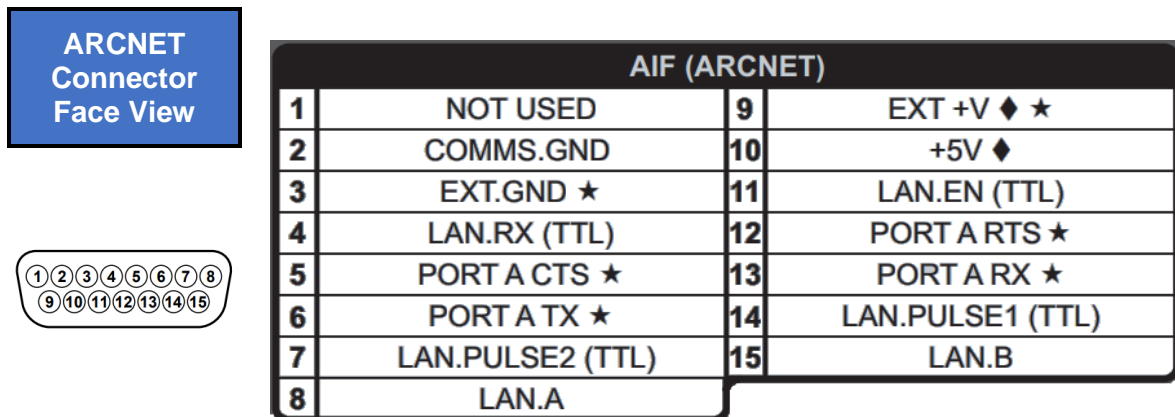

The voltage on pin 9 is selectable via an internal jumper, the factory default is 33 V / 31.5 V.

Tritech Micron Connector

A Tritech Micron tail (Part Number S05975) is supplied in 1 and 2 metre lengths and should be wired as follows:

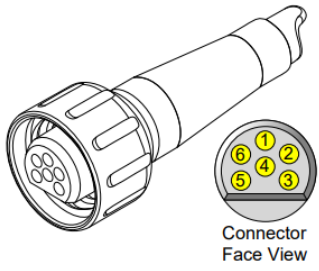
Connector Face View	PIN	Wire Colour	Function
	1	Yellow	RS485 A RS232 TX
	2	Blue	RS485 B RS232 RX
	3	Red	DC +
	4	Black	DC ground
	5	Green	RS232 ground
	6	Cable Sheath	earth



The Micron series connector is not wet mateable and direct exposure to water when the unit is powered will cause damage. Care should be taken when wiring the Micron Connector whip to the vehicle, as applying power to the Communication lines could damage the electronic equipment.

Micron Connector Installation Precautions:

- The connector sockets are not usable “open face” and should always be sealed with the blanking-plug provided, when not in use.
- Care should be taken when mating the connector, with either a plug or a blanking-plug, to ensure both mating ends are clean and dry.
- Special attention should be given to checking the O-ring for dirt. The O-ring is located under the lock-ring on both the plug and the blanking plug.
- The connector lock-ring needs only to be finger tight. The use of any tools to tighten the lock-ring further is not necessary and could result in damage to the connector.

Using the MicronNav Hub

Checking the MicronNav Hub Status

The MicronNav Hub has been designed to act as an interface device between the surface control computer, USBL Dunking Transducer and connected subsea equipment. As such, during normal operation there is little to no onscreen notification of the MicronNav Hub status.

The main means of checking the MicronNav Hub status are:

- The front panel of LEDs
- The Genesis Software Application

If an additional device is added, or the configuration of the system has to be changed then the front panel of the NavHub can be used as a primary diagnostic tool as it displays the communications for each port, as well as the activity currently active on it.

The top row of LEDs indicates the communication activity that is currently taking place on each port. A RED flash indicates communication from a device has been detected. A GREEN flash indicates communication from the NavHub has been detected. This can provide a visual aid in determining the status of equipment prior to any service work.

The next four rows of LEDs are used to indicate the communications protocol setup of each port. All four ports are capable of communicating on RS232 and RS485, but only certain ports are capable of communicating on ARCNET or RS422.

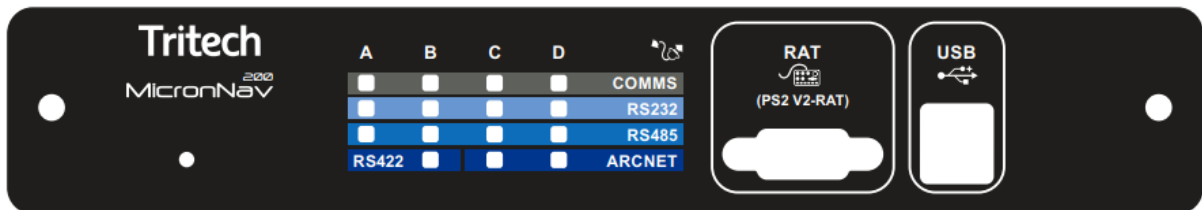

Protocol	Port A	Port B	Port C	Port D
RS232	Y	Y	Y	Y
RS485	Y	Y	Y	Y
RS422	N	Y	N	N
ARCNET	N	N	Y	Y



When Ports C and D are setup as ARCNET, the ports are electrically linked to the 15-way ARCNET port at the rear of the MicronNav Hub.

When changes are made to the configuration of the MicronNav Hub, all the LEDs will flash before the new configuration is displayed. During the reconfiguration process all communication to connected devices will be temporarily disrupted.

System Installation

Using the MicronNav System with Tritech Sonars

It is possible to operate the MicronNav with other Tritech Sonars in the same way as that detailed for the MKII/MKIII Micron. The following list provides details on MicronNav compatibility with the other Tritech Sonars:



The Micron Modem has a power range of between 12- 48 Volts and care should be taken not to exceed this.

Micron DST Sonar

This sonar requires a dual micron interconnect cable (**Part Number S06372**), and is available in 0.5 metre, 1 metre and 2 metre lengths. This type of sonar supports both Transponder and Responder modes of the Micron Modem.

Super SeaPrince Sonar/ Super SeaKing Sonar

The Super SeaPrince DST and the Super SeaKing DST Sonars, require the same Micron Standard to Tritech Connector Right Angle (R/A) cable (**Part Number S09819 0.5M**). This type of sonar supports both Transponder and Responder modes of the Micron Modem.

Gemini Multibeam Sonars

Transponder Mode is the only mode supported with the Gemini family of Multibeam sonars, as it only requires power. This is fed from the sonars Aux port and will require special cabling, please contact Tritech International Ltd. for more information.

Reducing Magnetic Interference

The MicronNav 200 software manual, contains instructions for the AHRS calibration procedure. This calibration counteracts potential environmental magnetic interference which could potentially affect the compass readings.

Mounting the USBL Dunking Transducer

The USBL Dunking Transducer may be secured with a 75mm diameter clamping mechanism, placed above the line shown on the Product label as below.



The Clamping Point for the USBL Dunking Transducer.

Positioning the USBL Dunking Transducer

The yellow line on the top of the USBL Dunking Transducer, indicates the front of the transducer head as can be seen in the illustration below. This should be positioned facing in the required forward position to the fixed platform, to ensure correct representation on the PPI display. When mounting on a vessel this should be pointed towards the bow.

The USBL Dunking Transducer should be mounted at least 2-3 metres away from the side wall of a Fixed Platform or Dockside and if possible the hull of a vessel.

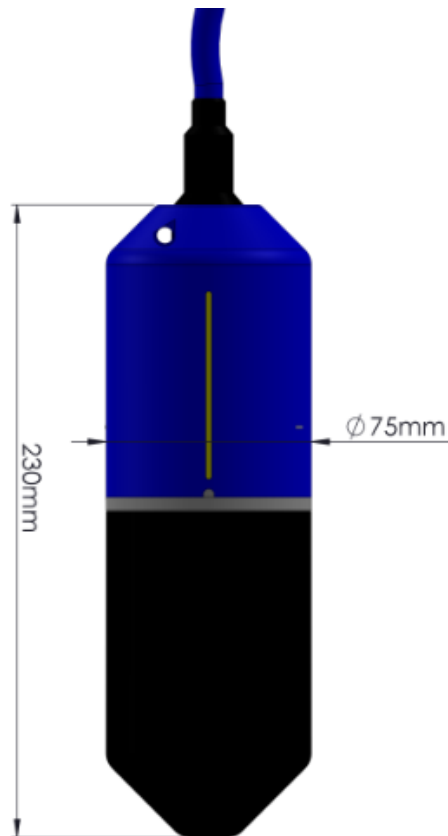

The yellow line indicating the front of the USBL Dunking Transducer.

Mounting Depth

Mount the USBL Dunking Transducer head at least 1 m to 2 m below the surface of the water.



The USBL Dunking Transducer head is rated to a depth of 30 m and must not exceed this depth.

Mounting the USBL Dunking Transducer to a Vessel

When positioning the USBL Dunking Transducer it may be difficult to achieve the recommended 2 m to 3 m clearance from the vessel's side. In this case it is recommended to lower the head deeper to ensure a clearance of 1 m to 2 m below the bottom of the hull. It is worth noting that the depths reported by the Transponder/Responder will be below this depth.

The yellow line on the outside of the Dunking Transducer should be orientated with the bow of the vessel.

USBL Dunking Transducer Deployment Speed

When operating the USBL Dunking Transducer from a vessel, consideration should be given to the speed the vessel is likely to be travelling at. As the resultant force/pressure on the USBL Dunking Transducer mounting arrangement, should be kept at a bare minimum. A recommend maximum speed for deployment would be between 2-5 knots.

System Mobilisation

The following assumes that the hardware and software have already been configured and tested topside.

Below is a series of checklists to follow, prior to the ROV/Diver being deployed into the water. The Pre-Dive check list should be carried out to ensure maximum reliability and performance from the system.

Pre-Dive ROV Installation Checklist

Check the connections to the Subsea Modem and Micron/Sonar (if fitted) are securely fastened (finger tight) and the blanking cap has been fitted to the AUX port of the subsea Modem

All cables are clear of the ROV thrusters

Fix the USBL Dunking Transducer (at least 2-3 metres away from ship's hull/dockside and 1 m deep)

For use with a vessel, orientate the yellow reference line pointing towards the bow of the ship

For use with a Fixed position/dock, point the yellow reference line at 90 degrees

Pre-Dive System Checklist

Apply power to the ROV or Modem (Diver) and Micron Nav System

Run the Genesis software and setup the application

Place the USBL Dunking Transducer next to the subsea Modem (10 cm) in a bucket of water to check the acoustic communications link is operating correctly.



To avoid internal damage to the transmit transducer, it should not be operated in air. Shut down the control software or unplug the unit before lifting out of the water.

Rotate the USBL Dunking Transducer and alter the pitch and roll, to check for the correct operation of the integral Heading/Pitch/Roll sensor (if this is being used)

Attach the USBL Dunking Transducer to the supplied 0.5 metre mounting pole

Fix the USBL Dunking Transducer rigidly at least 1 m away from ship/ dock wall and 1 metre below the surface, with the yellow line pointing in the ship's Bow direction or 90 degrees to the dock wall

If accuracy is required, measure and enter the USBL Dunking Transducer Offsets, covered previously in the Platform Configuration Section of the MicronNav Software Manual.

Operational Checklist

Deploy ROV/ Diver into the water

Dive to a depth 1 metre (below the dunker) and check position updates, move ROV/Diver, and check position trail on Genesis NAV Application screen matches ROVs actual movement by visual inspection

Dive to a depth 5 metres and move away 5 metres to check the reported USBL values/ positional updates are correct. Once satisfied that the readings are correct, commence with using the ROV/Diver.

The below table provides the user with a guide to testing their system. This also serves as a reference, should you need to contact Technical support and ask for help.

Configuration	ROV Name, S/N		
	MicronNav1.5 S/N		Dunk. Trans. S/N
	Software, Version	Genesis	Transponder S/N
Ground Tests	Check cable connections		
	Check Project Settings		
	Check position updates by mating Dunking Transducer and Transponder		
	Check position updates by move Dunking Transducer 10 cm away and above Transponder in a slow circular motion		
	Fix Dunking Transducer rigidly at least 1 m away from ship and below water surface, facing yellow line pointing in the ship's Bow direction		
Sea Tests	Deploy ROV into water, check ROV's and ship's yaw angle matches on NAV screen		
	Dive to 1 metre and check position updates, move ROV through markers, and check position trail on NAV screen matches ROVs actual movement by visual inspection.		
	Repeat following scenario for different depths, while checking position updates: Dive to 5 meters, Check that the USBL system is functioning correctly.		

Troubleshooting

When the unit is powered up nothing happens.

- Check that the front panel indicators have not been turned off under software control
- If using a “mains” AC source, check the fuse within the fuse drawer on the IEC power inlet connector at the rear of the unit.
- Check that the power supply requirements for either the AC (Mains) or DC source have not been exceeded.

If the unit still continues to be unresponsive, refer to Trittech Support for further help.

The USB link between the MicronNav Hub and the PC doesn't work.

- If using the USB cable supplied with the MicronNav Hub, check that the LEDs are illuminated within the cable connector mouldings
- This indicates that there is a voltage on the cable to the peripheral
- Check that the USB cable length doesn't exceed 5m
- Check that the MicronNav Hub USB port is not plugged into any intermediate hubs between the unit and the PC
- Use the “Microsoft Windows” hardware Device Manager to check that all the USB drivers are correctly installed and setup on the PC

The USB peripherals plugged into the front of the MicronNav Hub unit, don't work.

- Check that the MicronNav Hub is powered up correctly
- Check that the MicronNav Hub modules onboard peripherals and hub controller have correctly registered and detecting on the PC's operating system
- Check that all cables are correctly and firmly connected to their appropriate sockets
- Use the “Microsoft Windows” hardware Device Manager to check that all the USB drivers are correctly installed and setup on the PC
- Use the “Microsoft Windows” hardware Device Manager to check that the USB bandwidth available to connected peripherals versus their demands has not been exceeded
- Check that the connected USB peripheral is not exceeding the 500mA current limit on each USB port. Diagnostic LED's are available within the module to indicate this contact Trittech International Ltd for further details

The RAT does not work.

- Check that the RAT being used is labelled as a “Version 2, PS-2” RAT. The MicronNav Hub unit does not support previous versions (i.e. With Trackball instead of Togglestick pointer).

Check that the connection of the RAT has not caused the power supply requirements for either the AC (Mains) or DC source to be exceeded

The serial port device doesn't work in RS232 mode.

- Check RX and TX connections are correct on both ends – the MicronNav Hub is wired as a DTE, the same as a PC.
- Check that ground connections are correct, and made to the COMMS GROUND
- Check that baud rates and serial setup on both the device and the PC are correct
- Check the cable length used does not exceed the stated RS232 specification for the baud rate being used. – 10m or less for 115.2KBaud
- Check that if handshaking is required, Port A is being used (as it is the only port that supports RTS and CTS signals)
- Check that there are no short circuit faults on the RS232 signals, and voltage levels are between $\pm 5V$ and $\pm 15V$
- Check that no two conflicting devices have been connected, if using Port A, and the link connection to the AIF connector have been made
- Check the port is correctly configured as RS232 mode through the Genesis configuration interface
- If the device is drawing power from the MicronNav Hub, check that the power supply requirements for either the AC (Mains) or DC source have not been exceeded

The serial port device doesn't work in RS485 mode.

- Check A and B wiring connections are correct on both ends or any interconnect cabling, and not crossed
- Check that baud rates and serial setup on both the device and the PC are correct
- Check the cable length used does not exceed the stated RS485 specification for the baud rate being used
- Check that there are no short circuit faults on the RS485 signals, and voltage levels are 5V
- Check the port is correctly configured as RS485 mode through the Genesis Setup configuration interface
- Check that the correct termination has been fitted to the cable (approx. 150Ω)
- Check that the half-duplex turnaround time is less than a half baud period on the RS485 device

If the device is drawing power from the MicronNav Hub, check that the power supply requirements for either the AC (Mains) or DC source have not been exceeded

Maintenance

General guidance

Although the MicronNav hardware is not field serviceable regular care and maintenance of all items should be carried out.

The body section of the standard modem units and battery modems are protected from corrosion by a hard anodised passive surface film. This offers excellent protection in general operating conditions. However, without routine maintenance and in extended immersion in sea water, particularly at raised temperatures and salinity, the chlorides from the salt will start to attack this passive layer. To prevent such damage wash down the modem units post-dive to disperse contaminants such as salt deposits but care should be taken not aim high pressure water jets near sealing interfaces. A blanking cap should always be fitted on the standard modem AUX port (if not utilised) before the unit is taken subsea.



Ensure blanking caps are fitted to both MAIN & AUX ports on the Battery Modem before the unit is taken subsea.

The Dunking transducer and cabling should be washed down post-dive to remove contaminants such as salt deposits,

Regular visual inspection of all hardware around the areas where salt build up can occur will help highlight any potential issues of corrosion and allow for corrective action to be undertaken before any integrity failure of the unit. Particular attention should be given to the area around the pressure relief valve on the battery modem as this is an area where there is potential for debris and deposits to build up.

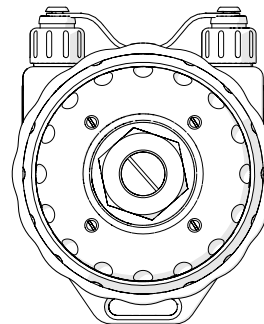

After Use

After using the equipment ensure all subsea items are washed down with fresh water and check items for any signs of obvious damage. Once the items are clean; dry thoroughly and place in storage container or dedicated transit case provided.

Equipment Storage

Make sure items are completely dry with no signs of moisture on any of the connectors. Fit all blanking plugs to the modem units and pack into an appropriate storage container along with several pouches of silica gel.